

Notes

1. Alternative Main Pin-20 to P1E4, instead of P2G4, MAY result in a cleaner TPS signal
2. "Handlebar switch right hand kill on-off and start", Hi Level #694605, from www.patternbikes.com
3. Map 1 : switch ON (right) : pin 19 LOW
4. Kill switch is active when it is in the RUN position ! The marking is wrong for the Tornado circuit.

Title

Standard Tornado AFR Tuner Wiring

Size	Number	Revision
A4		00
Date:	20-Mar-2011	Sheet of
File:	C:\Documents and Settings\errol\My Documents\Dropbox\Tornado\Wiring\AFR Tuner	

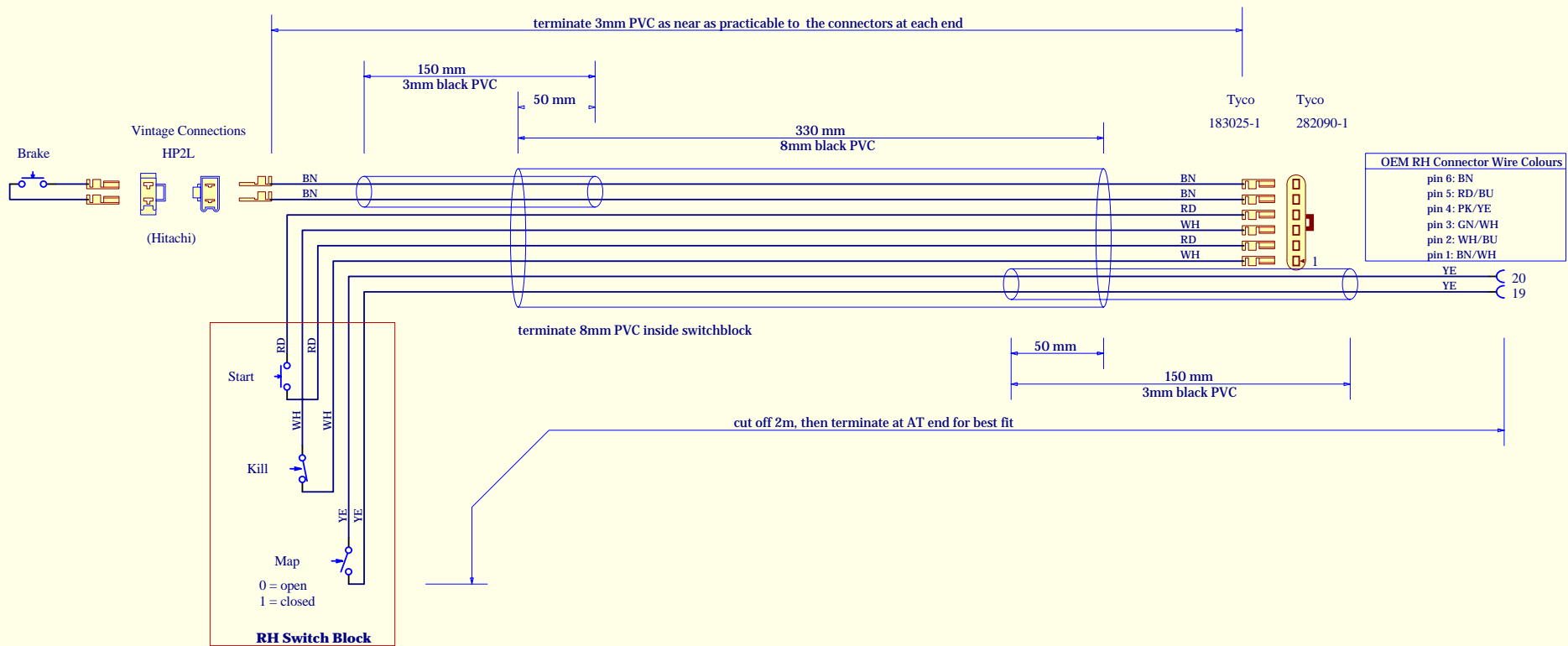

Notes

1. RH Switchblock: "Handlebar switch right hand kill on-off and start", Hi Level #694605, from www.patternbikes.com
2. Map 1 : switch ON (right) : pin 19 LOW
3. Kill switch is active when it is in the RUN position ! The marking is wrong for the Tornado circuit.
4. The Map switch will be marked "ON" at the left and "OFF" at the right position. Use a scalpel to carefully remove the 'N', 'O' and first 'F', then the horizontal strokes of the second 'F', to reveal '0' and '1'.
5. add a small bend to each retaining tab of the kill switch, to increase the retention overlap, and reduce the possibility of the switch opening up with use.
6. All switchblock wiring is 0.5mm2 (20 AWG)

Title			Modified RH Switchblock Wiring		
Size	Number	Revision			
A4		00			
Date:	20-Mar-2011	Sheet of			
File:	C:\Documents and Settings\errol\My Documents\Dropbox\Tornado\Wiring\AFR				